

**MATERIAL SPECIFICATION**

**CLIP**

PEZ : EN10139-DC04 - BRIGHT ZINC PLATED  
 PES : EN10088-2 : 1.4301 (BS304) - STAINLESS STEEL

**LINER**

TYPE R : (STANDARD) - BLACK - DATA SHEET D103  
 TYPE H : (HIGH TEMP) - GREY - DATA SHEETS D101/D103

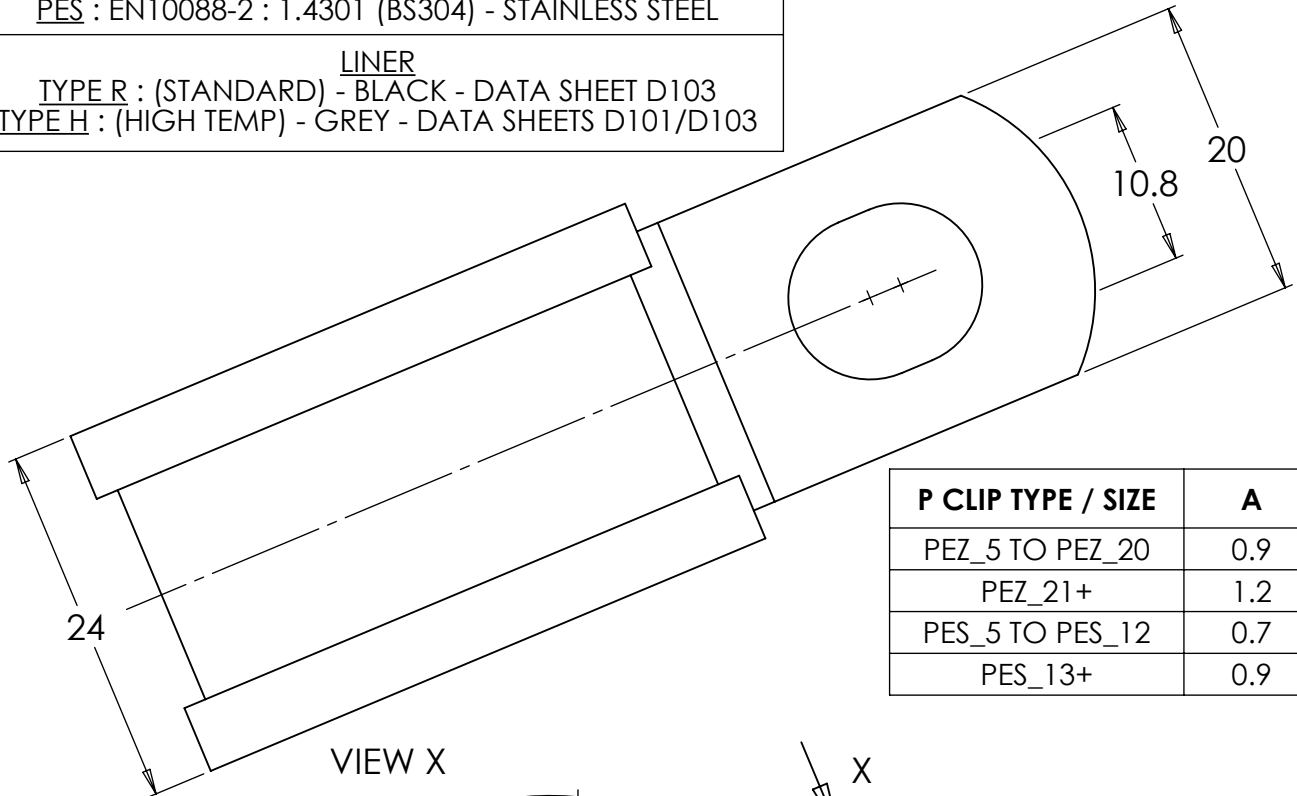

P CLIP TYPE / SIZE	A
PEZ_5 TO PEZ_20	0.9
PEZ_21+	1.2
PES_5 TO PES_12	0.7
PES_13+	0.9

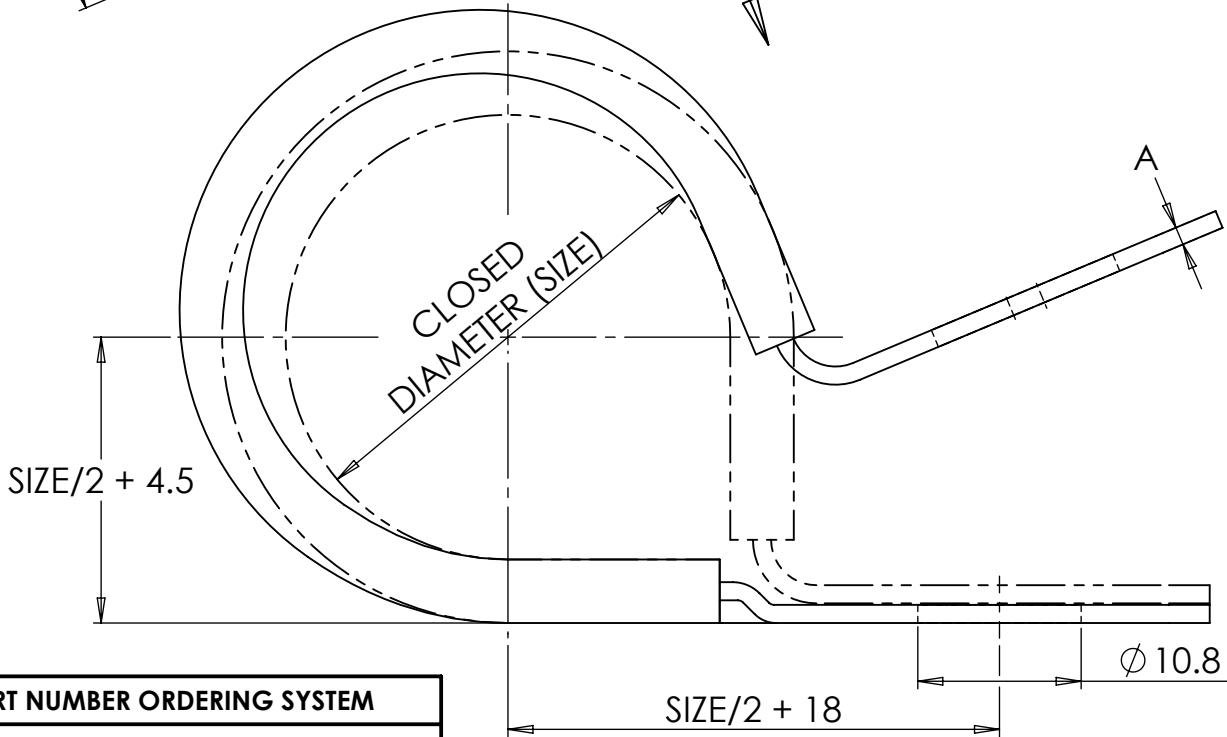

**PART NUMBER ORDERING SYSTEM**

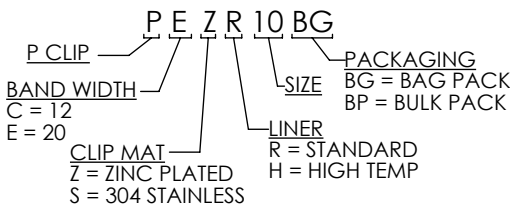

**REVISIONS**

DATE	ISSUE No.	MODIFICATION
06/01/16	1	NEW DRAWING

ALL DIMENSIONS IN MILLIMETERS	SCALE 2:1	SHEET A4	DRAWN BY CJP	DATE DRAWN 06/01/2016
THIRD ANGLE PROJECTION	DRAWING TITLE <b>P CLIP - M10</b>			
UNSPECIFIED TOLERANCES	FILE NAME 2012_01 - P Clip - M10			
NO DECIMAL = ± 1mm	DRAWING NO. 2012			
1 DECIMAL = ± 0,1mm	ISSUE No. 1			
2 DECIMAL = ± 0,01mm	SHEET 1 OF 1			
ANGLES = ± 1/4°				
DO NOT SCALE DRAWING	CHILTON INDUSTRIAL ESTATE SUDBURY, SUFFOLK, ENGLAND. CO10 2YH Tel: (01787) 376212 Fax: (01787) 880633			